

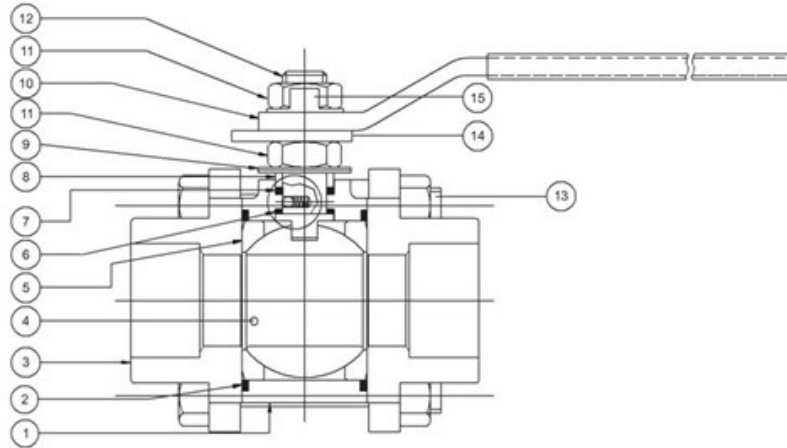

SPECIFICATIONS

Three Piece, Full Bore/Reduced Bore Design, Blow out proof stem & floating ball design.

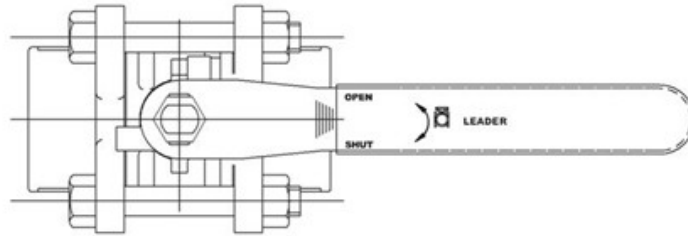

STANDARD MATERIAL COMBINATION				
P.NO	DESCRIPTION	Carbon steel to ASTM	Stainless steel to ASTM	Stainless Steel to ASTM
1	BODY	A105	A351 CF8	A351 CF8M
2	BODY SEAL	GRAPHOIL		
3	PIPE CONNECTOR	A105	A351 CF8	A351 CF8M
4	BALL	A276 304	A276 304	A316
5	SEAT	VIRGIN UNFILLED OIL FREE PTFE	Graphoil (Fire Safe only)	
6	STEM SEAL	VIRGIN UNFILLED OIL FREE PTFE	Graphoil (Fire Safe only)	
7	GLAND SEAL	VIRGIN UNFILLED OIL FREE PTFE	Graphoil (Fire Safe only)	
8	GLAND	A276 304	A276 304	A276 316
9	WASHER	CORBON STEEL		
10	LEVER	CORBON STEEL		
11	NUTS	A410	A304	A316
12	STEM	A276 304	A276 304	A276 316
13	BOLTS	A193 B7	A193 B8	A193 B8
14	STOPPER PLATE	CARBON STEEL		
15	LOCKING WASHER	Type 304	Type 304	Type 316

NOTE: The above data is subject to change without notice due to our continuing product improvement program.

(01)



JAYARAJ PIPE TRADERS

48/425 Q, JAYARAJ HOUSE, ELAMAKKARA, COCHIN 682 026
 TEL. No. 0484 253 0785, 240 8008, 240 8009. FAX: 0484 253 0785
 E-mail: jaypipescochin@gmail.com, sales@jayarajpipes.com
 Web: www.jayarajpipes.com



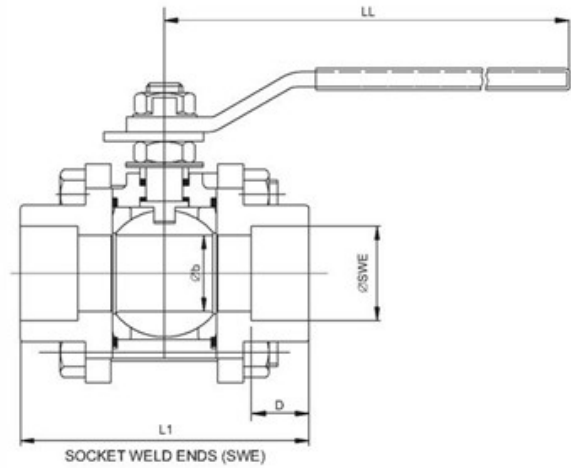
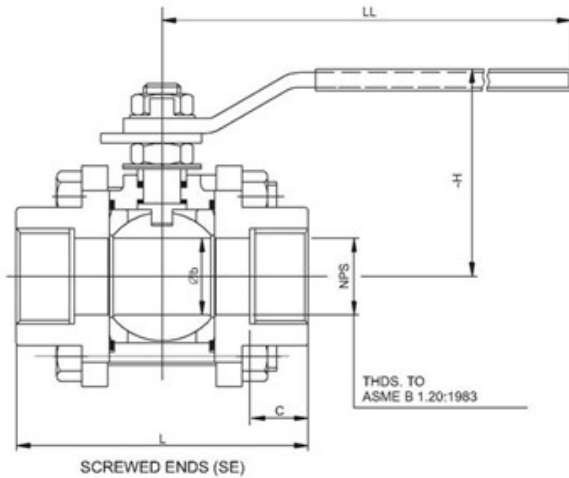

DIMENSIONAL DATA CLASS - 800

DN	NPS	φb	L(SWE)	L1 (SWE)	C	H	LL	φSWE		D	Aprox.Wt. ^
								BS 3799	ASME B16.11		
15	1/2	9	60	60	14.5	80	165	+0.3 21.7 -0.0	22.2 21.8	11	0.700
20	3/4	12.5	70	70	14.5	82	165	+0.3 27.4 -0.0	27.6 27.2	14	0.750
25	1	19	85	85	18	103	180	+0.3 33.8 -0.0	34.3 33.9	14	1.44
32	1 1/4	25	95	95	19	112	180	+0.3 42.5 -0.0	43.1 42.7	14	2.6
40	1 1/2	32	110	110	20	118	230	+0.3 48.6 -0.0	49.2 48.8	14	3.18
50	2	40	120	120	20	122	272	+0.3 61.6 -0.0	61.7 61.2	17	3.285

TEST PRESSURES

CLASS	SHELL TEST (HYDROSTATIC)		SEAT TEST			
			HYDROSTATIC		PNUEMATIC	
800	207 Bar g	3002 Psi g	152 Bar g	2204 Psi g	6.9 bar	100 Psi g

NOTE: The above data is subject to change without notice due to our continuing product improvement program. (^WEIGHT GIVEN IN KGS)

(02)



JAYARAJ PIPE TRADERS

48/425 Q, JAYARAJ HOUSE, ELAMAKKARA, COCHIN 682 026
 TEL. No. 0484 253 0785, 240 8008, 240 8009. FAX: 0484 253 0785
 E-mail: jaypipescochin@gmail.com, sales@jayarajpipes.com
 Web: www.jayarajpipes.com

